

ASSEMBLY INSTRUCTION

MODEL NO: B3450 / B3550 / B3650 / B3850 / B3950 - F - HBBFB FULL BED
FOR HEADBOARD/FOOTBOARD

(BOX 1)
BOX OF HEADBOARD & FOOTBOARD

ITEM	DRAWING	DESCRIPTION	Q'TY
A		HEADBOARD PANEL	1
B		LEFT HEADBOARD LEG	1
C		RIGHT HEADBOARD LEG	1
D		FOOTBOARD PANEL	1
E		LEFT FOOTBOARD LEG	1
F		RIGHT FOOTBOARD LEG	1

(BOX 1)
HARDWARE LIST FOR STEP1 & STEP2

ITEM	DRAWING	DESCRIPTION	Q'TY
1		BOLT	12
2		SPRING WASHER	12
3		FLAT WASHER	12
4		WOOD PLUG	4
5		ALLEN KEY	1
6		WOOD DOWEL	8

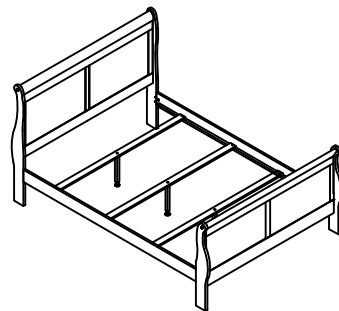

**COMPLETED FULL BED
ASSEMBLY**

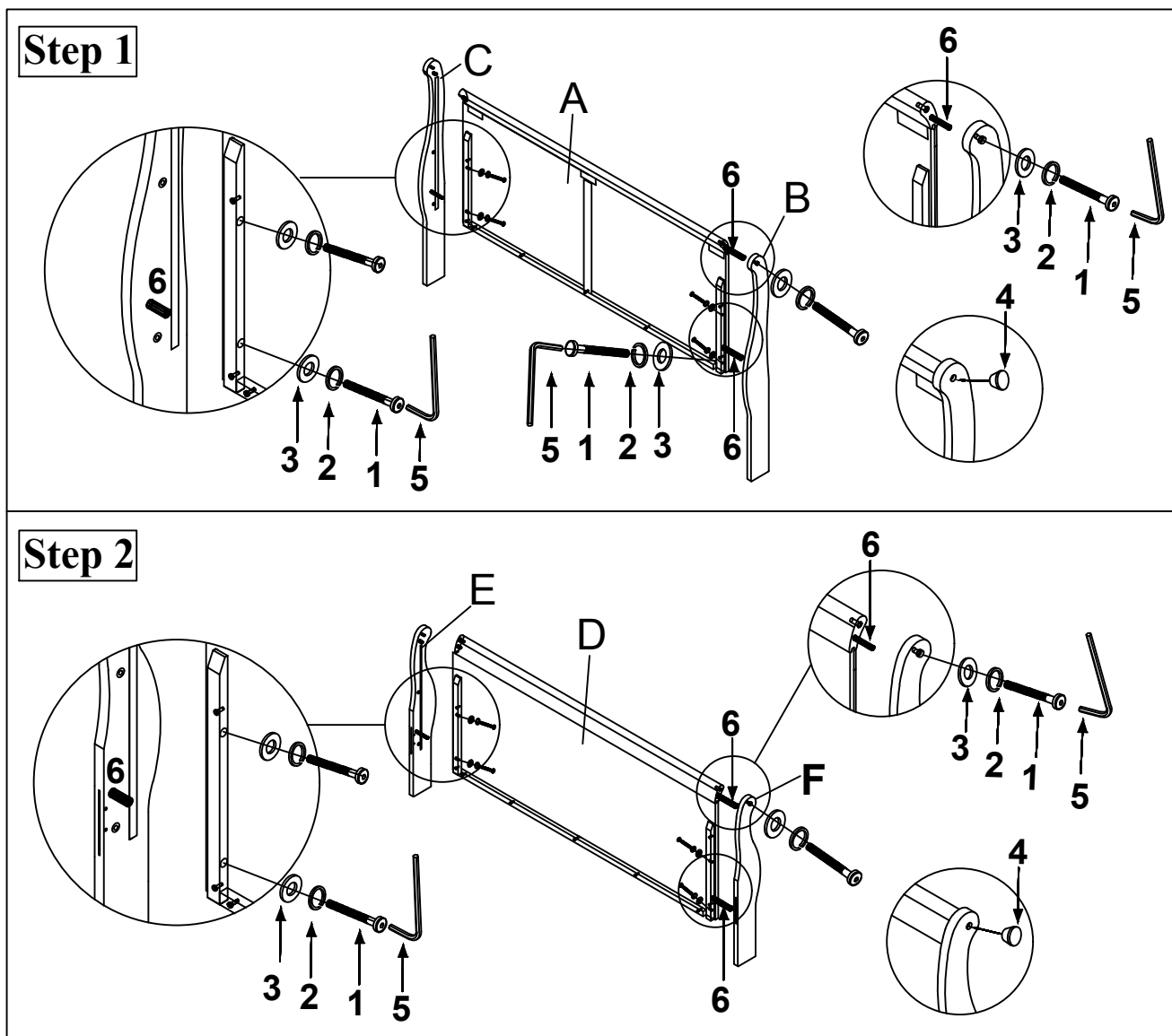

THE HARDWARE IS LOCATED IN THE PACKING ITEMS

NOTE: MUST TIGHTEN SCREWS PERIODICALLY WITH USE SCREWS MAY BECOME LOOSE.

CHECK TIGHTNESS OF ALL SCREWS EVERY 6-8 WEEKS.

CLEANING INSTRUCTION



After assembled, clean & polish the completed parts if necessary with soft cloth and industrial recognized furniture polish.

MADE IN VIETNAM



ASSEMBLY INSTRUCTION

MODEL NO: B3450 / B3550 / B3650 / B3850 / B3950 - T - RAIL
FOR SIDE RAIL

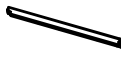

(BOX 1)
BOX OF HEADBOARD & FOOTBOARD

ITEM	DRAWING	DESCRIPTION	Qty
A		HEADBOARD	1
B		FOOTBOARD	1

(BOX 2)
BOX OF SIDE RAIL

ITEM	DRAWING	DESCRIPTION	Qty
C		SIDE RAIL	2
D		WOODEN SLAT	3
E		WOODEN SUPPORT	3

(BOX 2)
HARDWARE LIST

ITEM	DRAWING	DESCRIPTION	Qty
1		CB SCREW (M4 *28mm)	6
2		SCREW DRIVER(*)	1

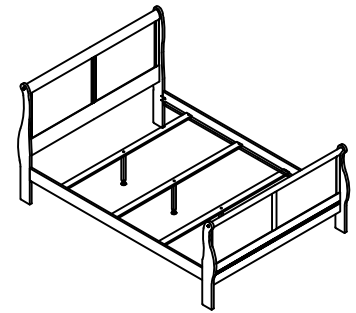

**COMPLETED FULL BED
ASSEMBLY**

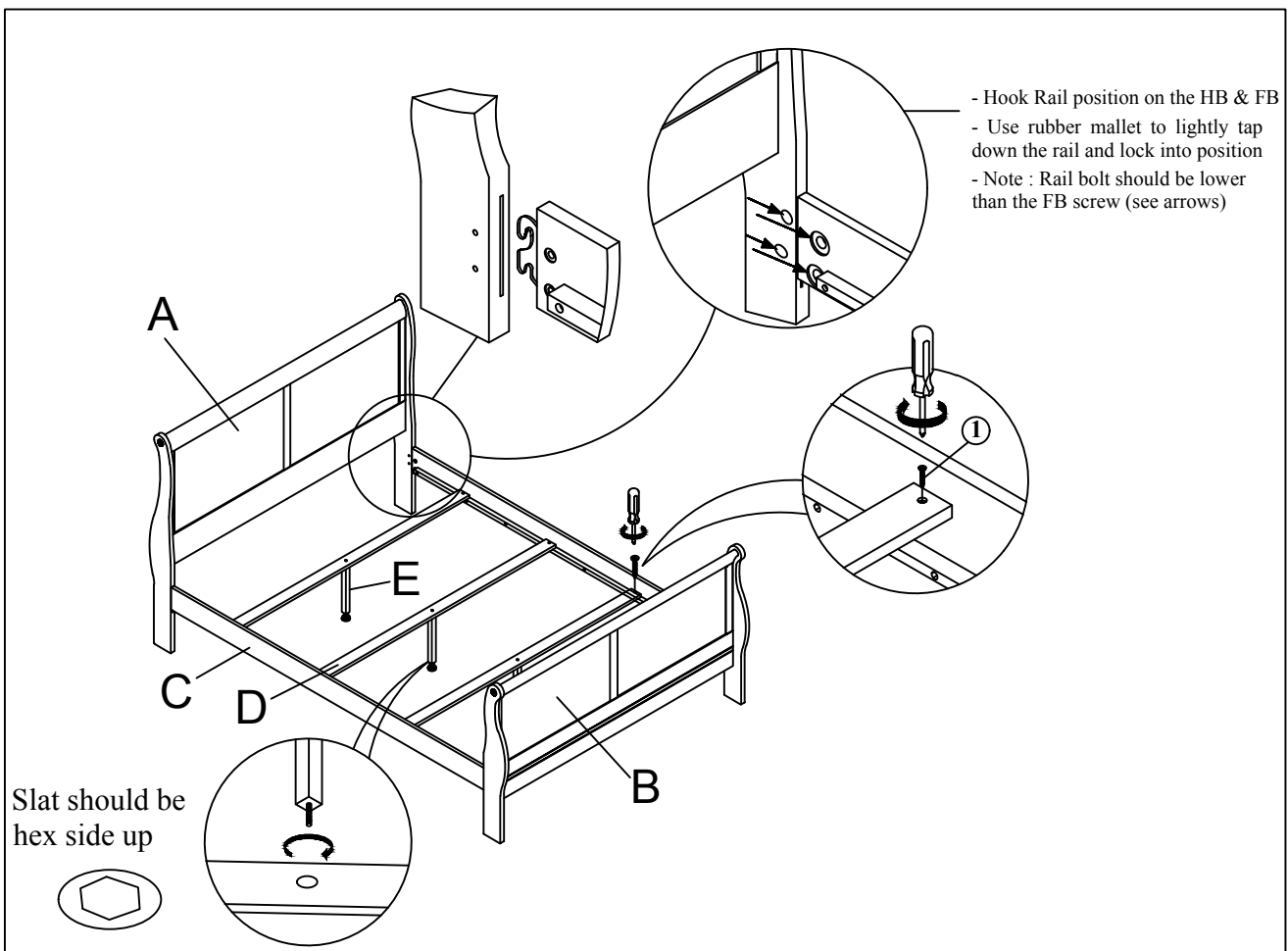

THE HARDWARE IS LOCATED THE PACKING ITEMS

NOTE: MUST TIGHTEN SCREWS PERIODICALLY WITH USE SCREWS MAY BECOME LOOSE.

CHECK TIGHTNESS OF ALL SCREWS EVERY 6-8 WEEKS.

CLEANING INSTRUCTION

After assembled, clean & polish the completed parts if necessary with soft cloth and industrial recognized furniture polish.

MADE IN VIETNAM



ASSEMBLY INSTRUCTION

MODEL NO: B3650 - 1 & -11
DRESSER & MIRROR

(BOX 1)
BOX OF DRESSER

ITEM	DRAWING	DESCRIPTION	Qty
A		Dresser	1

(BOX 2)
BOX OF MIRROR

ITEM	DRAWING	DESCRIPTION	Qty
A		Mirror	1
B		Mirror support	2

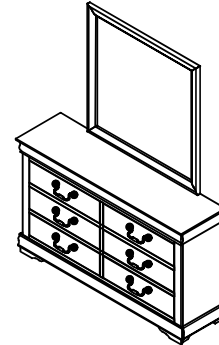

**COMPLETED
DRESSER & MIRROR
ASSEMBLY**

(BOX 2)
HARDWARELIST

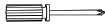
ITEM	DRAWING	DESCRIPTION	Qty
1		CB Screw (M4*35mm)	2pcs
2		SCREW DRIVER (*)	1pcs

The manufacturer does not provide item 2.

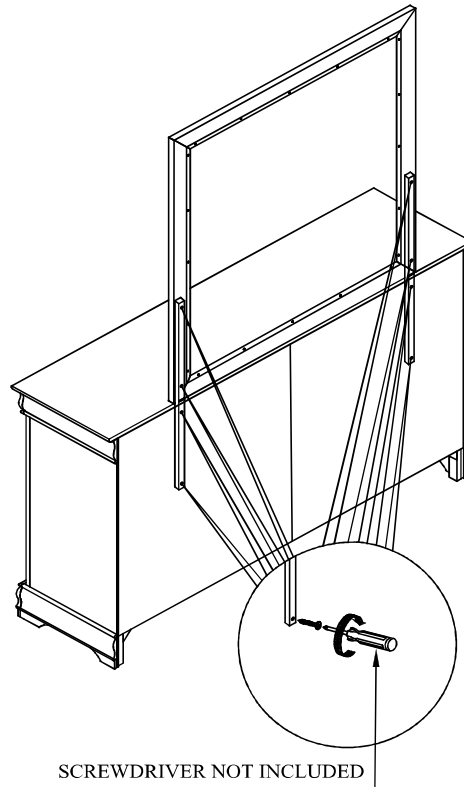

THE ANTI TIPPING HARDWARE IS LOCATED IN THE RIGHT SIDE FRONT DRAWER OF DRESSER.

NOTE: MUST TIGHTEN SCREWS PERIODICALLY WITH USE SCREWS MAY BECOME LOOSE.

CHECK TIGHTNESS OF ALL SCREWS EVERY 6-8 WEEKS.

CLEANING INSTRUCTION

After assembled, clean & polish the completed parts if necessary with soft cloth and industrial recognized furniture polish.

MADE IN VIETNAM